

I-LSL-BE 1

INVERTED LIFT SYSTEM FOR BOX ENCLOSURE

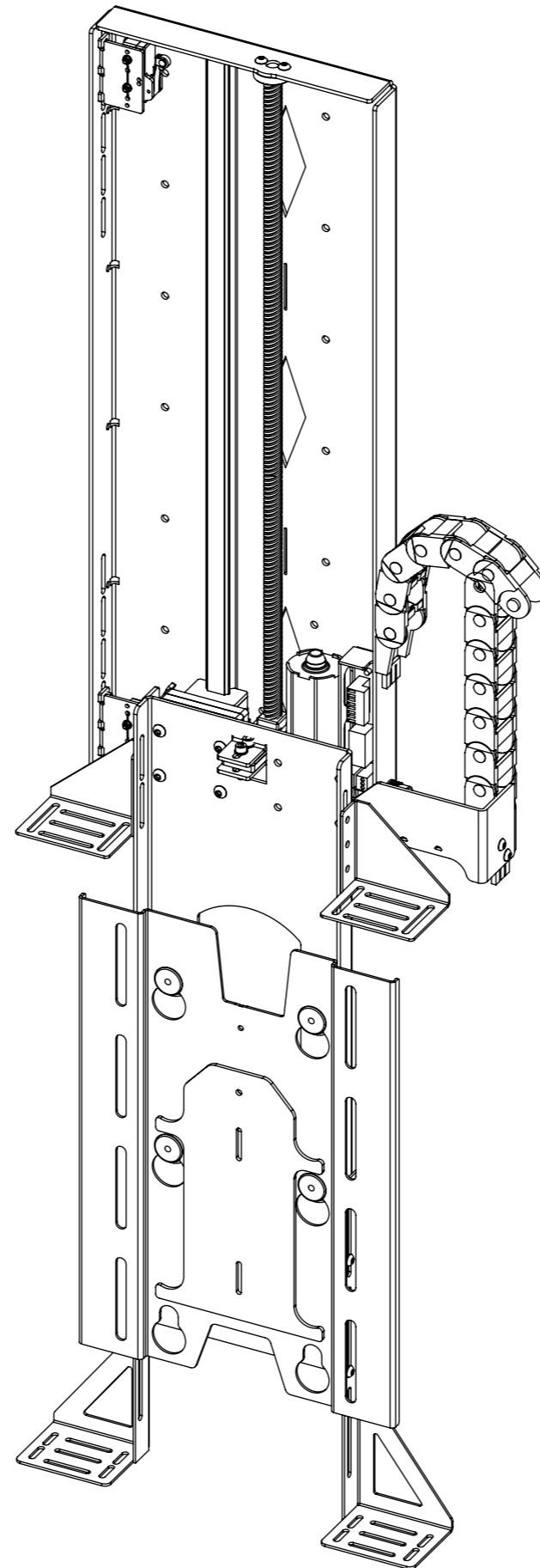

future automation



I-LSL-BE 1

INVERTED LIFT SYSTEM FOR BOX ENCLOSURE



SPECIFICATION	MEASUREMENTS
Screen Sizes (Approx)	19" - 32"
Maximum Weight Capacity	25Kg (55lb)
Maximum Weight Capacity (Marine)	16Kg (35lb)
Maximum Screen Height	410mm (16.14")
Packaging Dimensions	920mm (36.2") x 550mm (21.7") x 250mm (9.8")
Shipping Weight	15Kg (33lb)
Movement Type	Motorised
Power Supply Required	110V or 240V AC
Power Consumption	250-500W
Power Consumption Standby	3W
Decibel Rating	58dB
Mounting Patterns Supported	VESA 200 W x 300, 200 H
Control Options	IR Remote, RS232, Contact Closure
Product Options / Features	Specific B&O and Loewe mounts / adapters, Custom RAL paint finishes, Outdoor version
Package Contents	Mechanism, IR remote control
Marine Suitable	Yes (Indoor)

I-LSL-BE 1

INVERTED LIFT SYSTEM FOR BOX ENCLOSURE



CABLE ROUTING

Screen cables are routed behind the Base Panel and out the right side of the Beam into the Cable Track. Cables must be routed carefully to prevent any interference with the LSL beam as it operates.

Screen and Mechanism cables should be routed to a control box in the bottom of the cabinet.

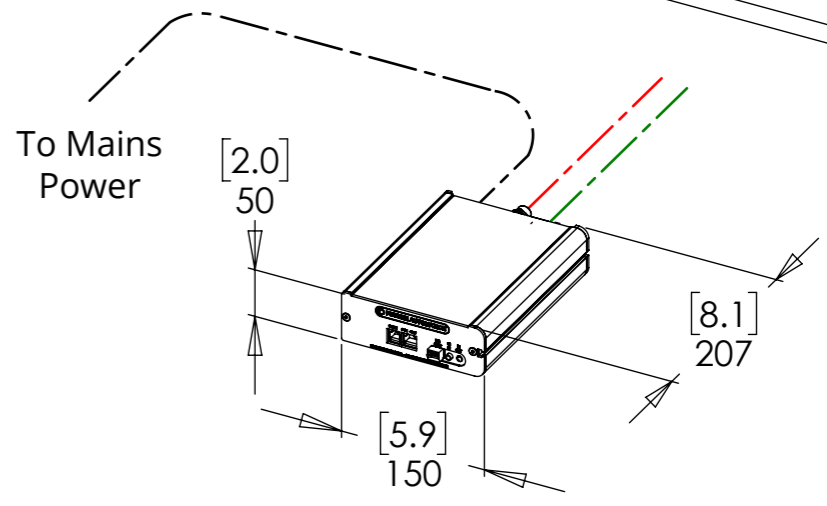
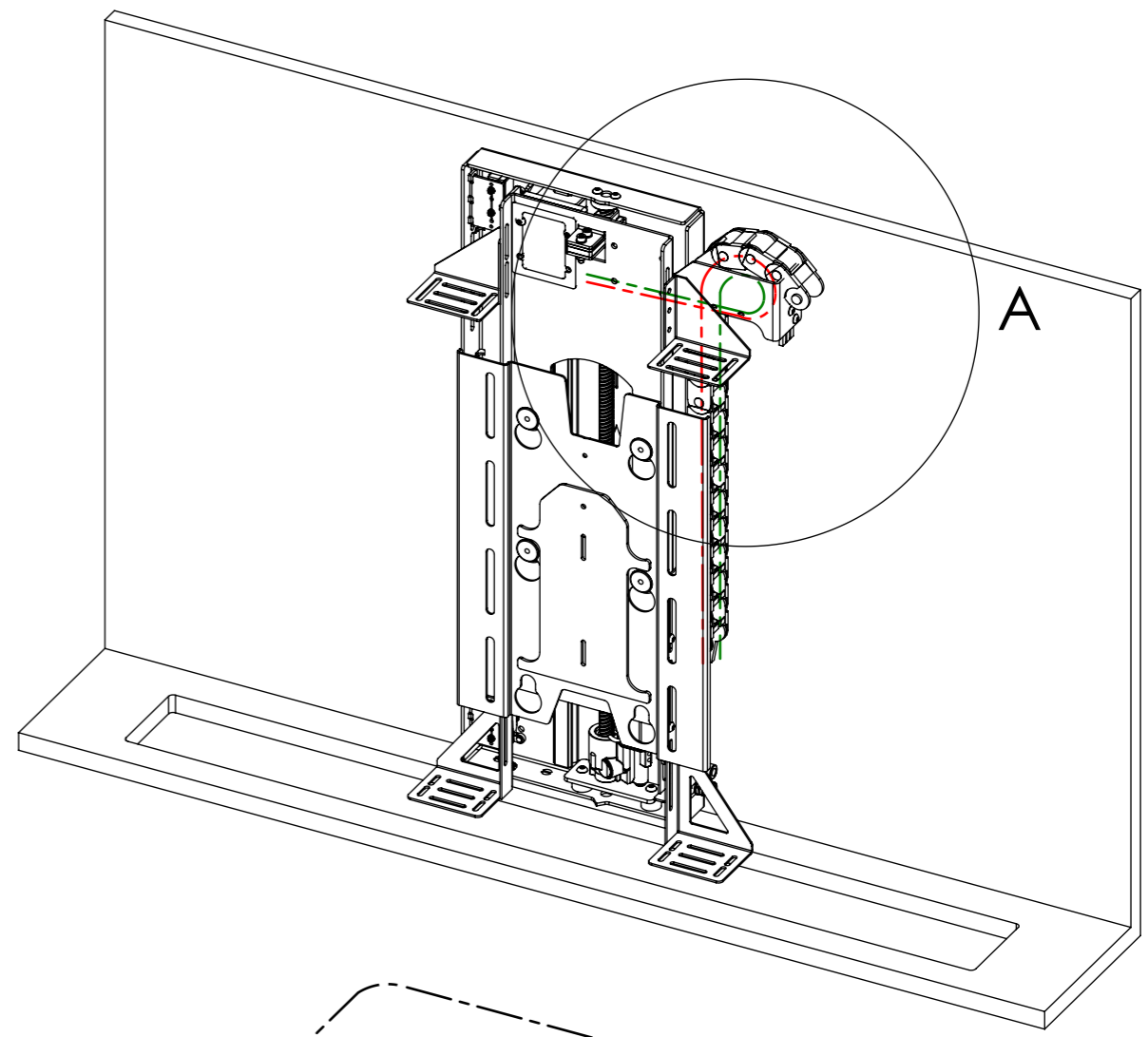
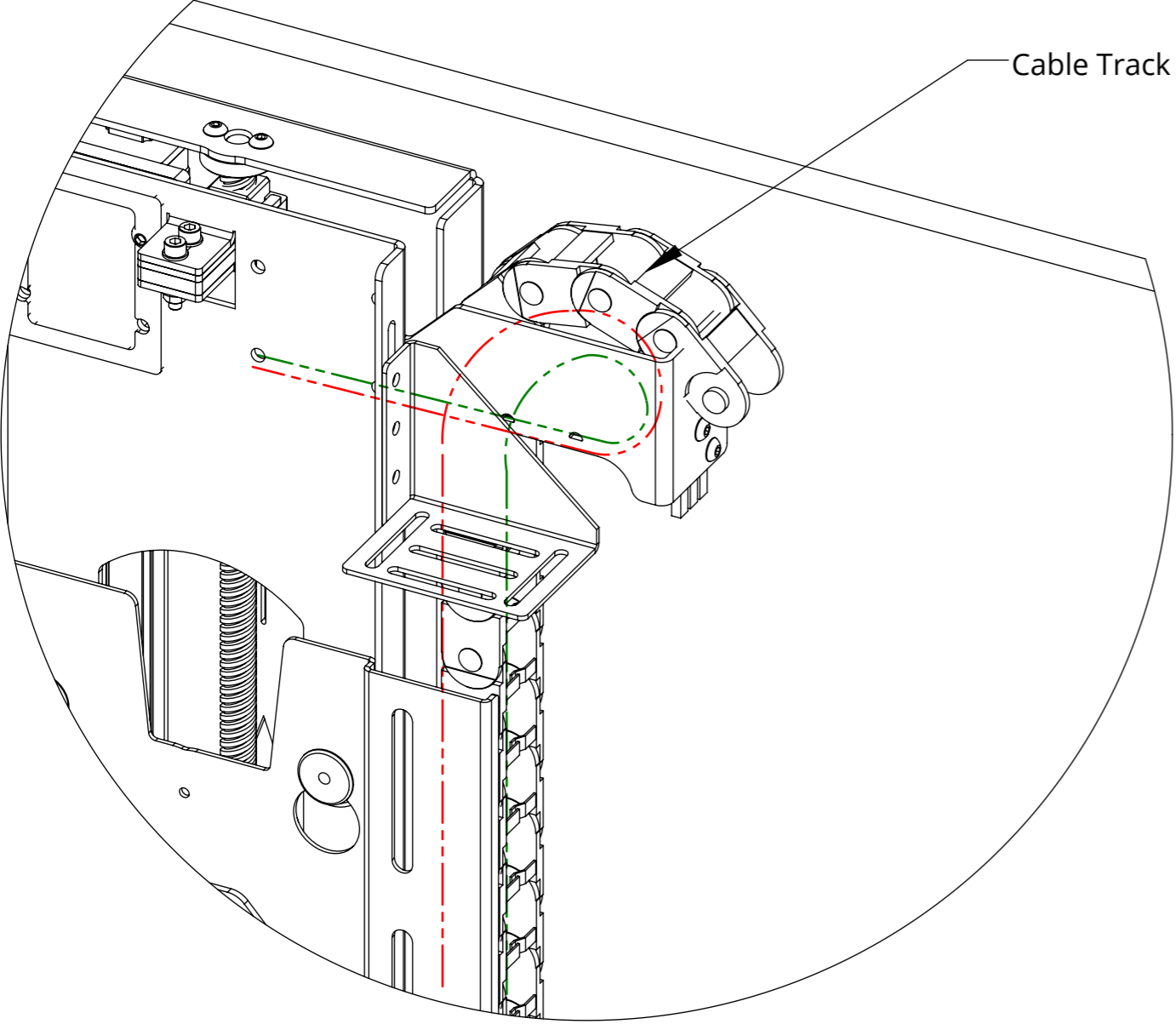

I-LSL-BE 1

INVERTED LIFT SYSTEM FOR BOX ENCLOSURE



MECHANISM UP - IN CABINET

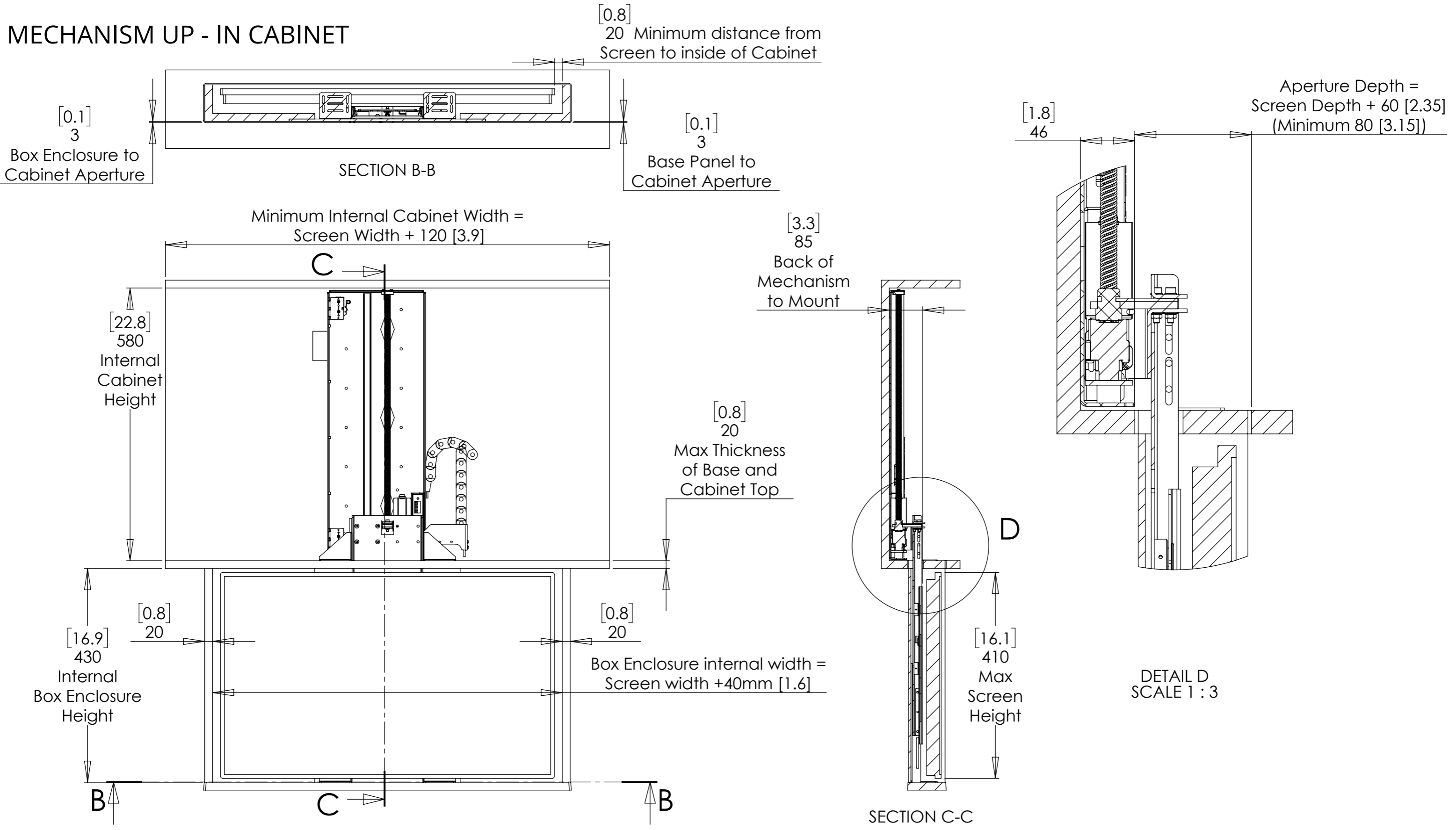

I-LSL-BE 1

INVERTED LIFT SYSTEM FOR BOX ENCLOSURE



future automation

MECHANISM DOWN - IN CABINET

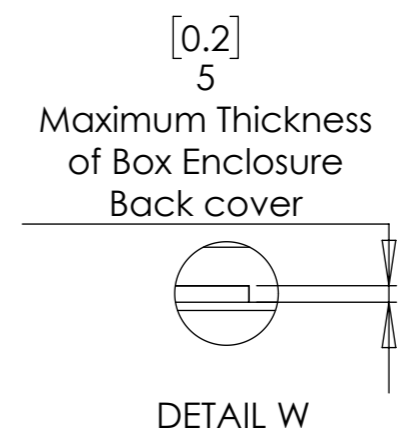
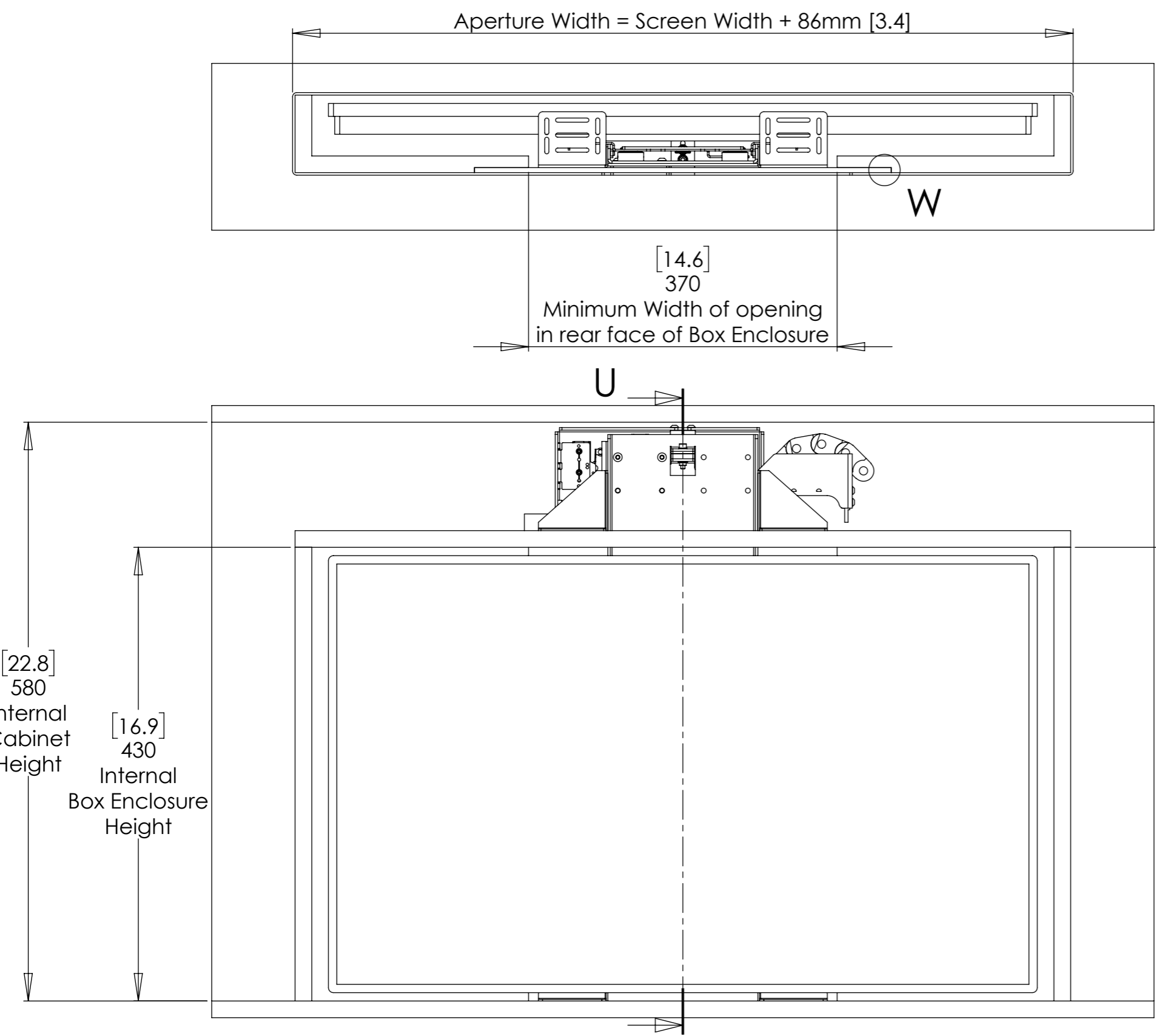

Shown with a tapered Box Enclosure Lid in a square Cabinet Aperture.

A tapered Cabinet Aperture can be used to improve the fit

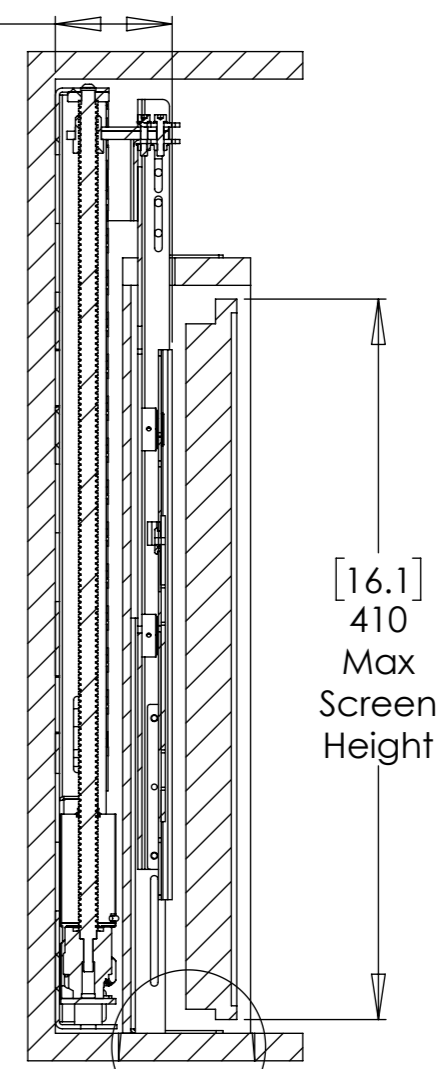
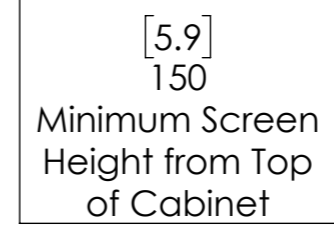
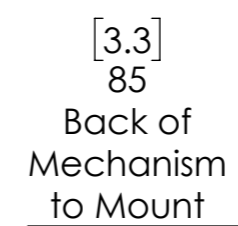
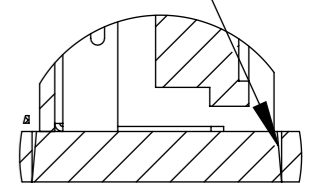

SECTION U-U

TECHNICAL SHEET
ISSUE 005
SHEET 5

I-LSL-BE 1

INVERTED LIFT SYSTEM FOR BOX ENCLOSURE



BASE PANEL & ENCLOSURE LID DETAILS

NOTE: A tapered Box Enclosure Lid creates a good fit in the Cabinet Aperture and helps the Box Enclosure to locate within the Cabinet.

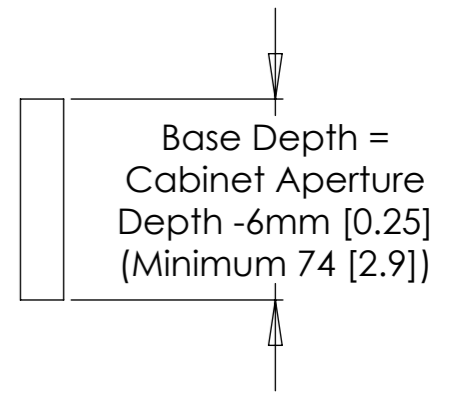
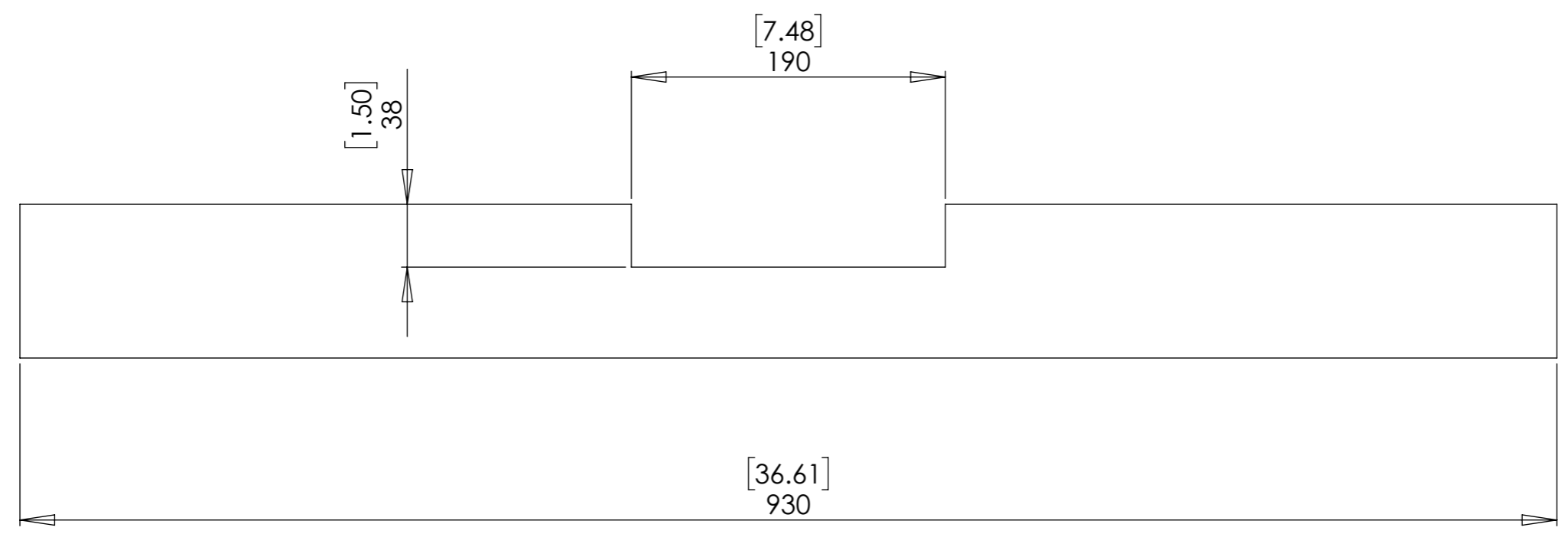
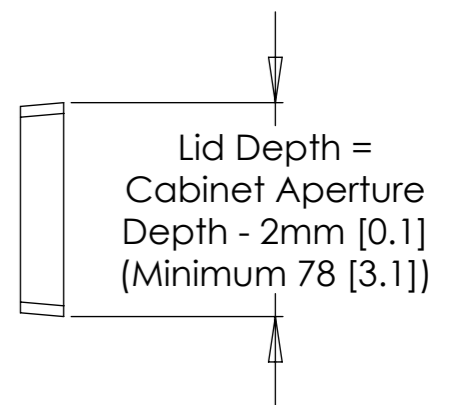
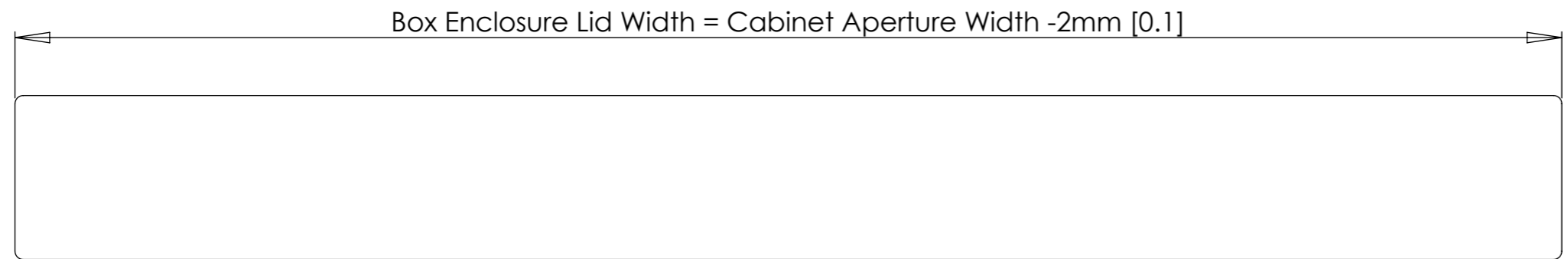

I-LSL-BE 1

INVERTED LIFT SYSTEM FOR BOX ENCLOSURE



future automation

OVERALL MECHANISM DIMENSIONS

MECHANISM DOWN

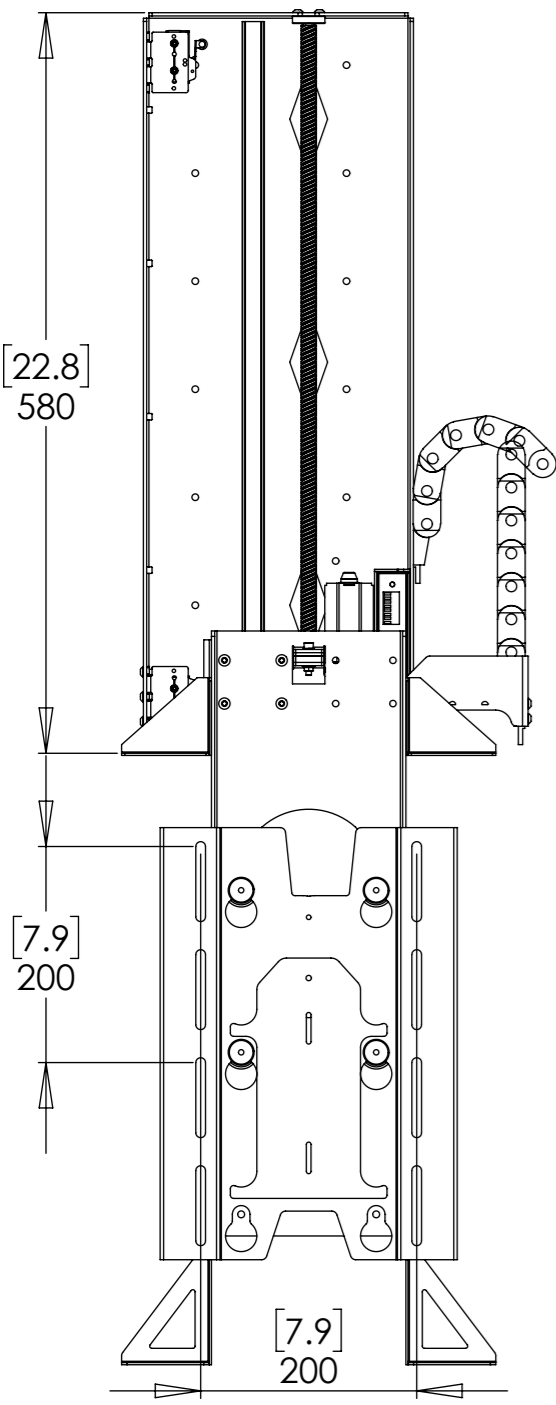

MECHANISM UP

