

LSL-BE/PF 3

LIFT SYSTEM FOR BOX ENCLOSURE/PUSH FLAP

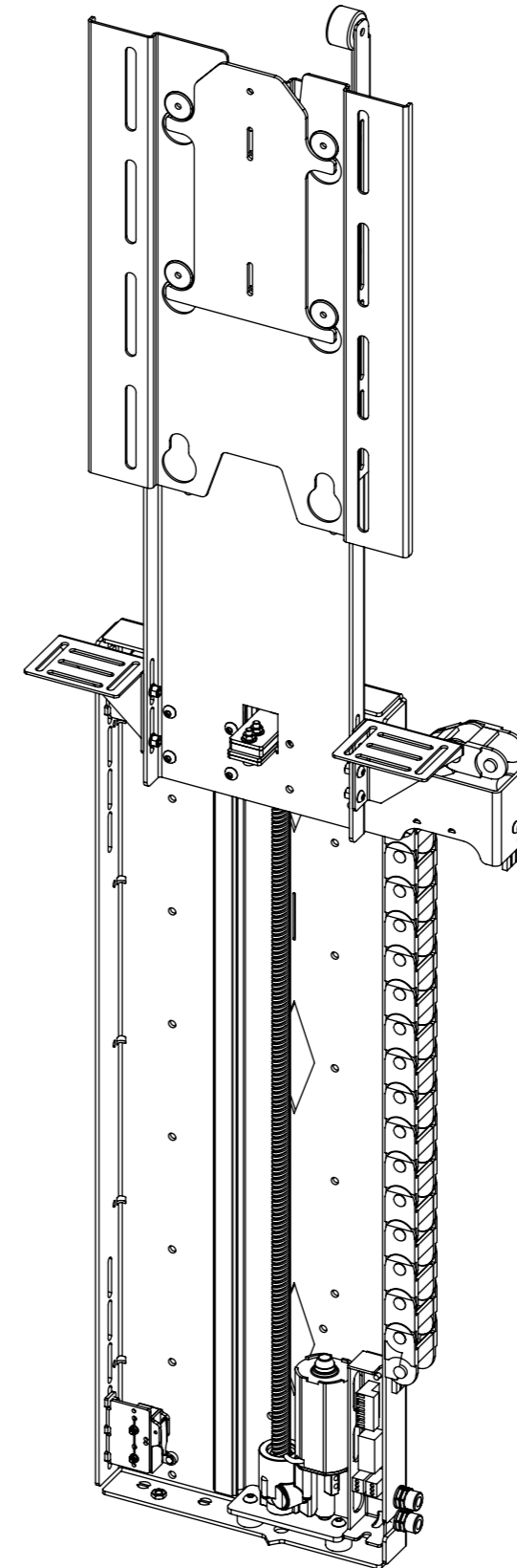

future automation

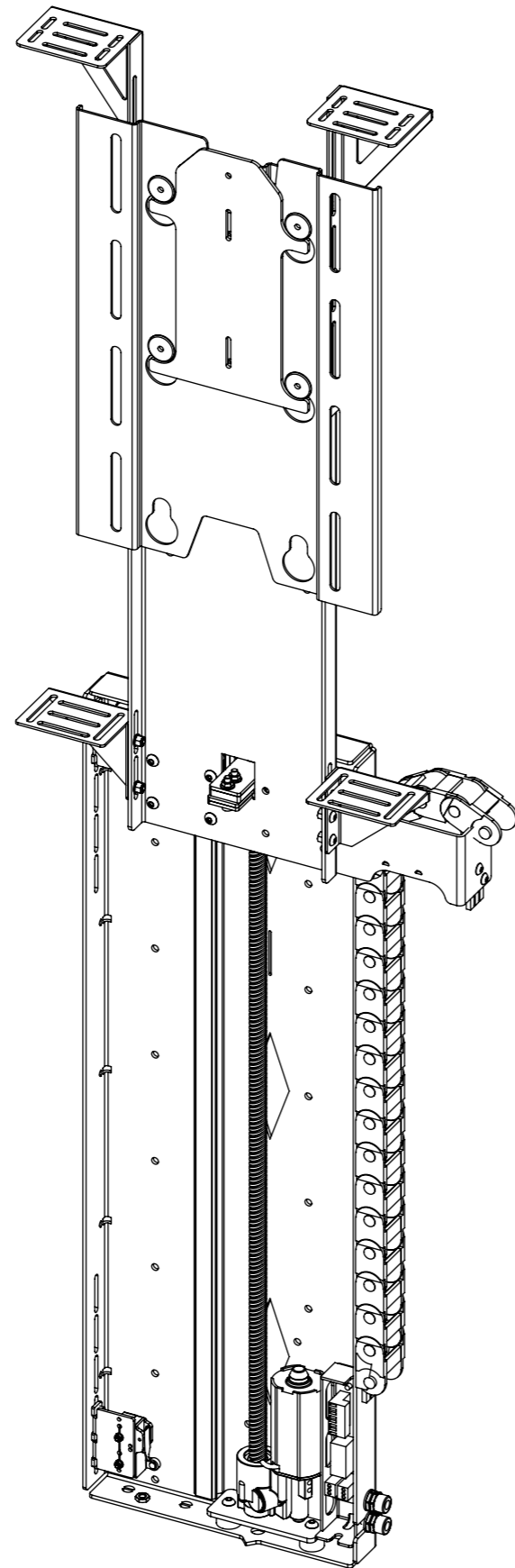

LSL-BE/PF 3

LIFT SYSTEM FOR BOX ENCLOSURE/PUSH FLAP



future automation

SPECIFICATION	MEASUREMENTS
Screen Sizes (Approx)	40"
Maximum Weight Capacity	25Kg (55lb)
Maximum Weight Capacity (Marine)	16Kg (35lb)
Maximum Screen Height	599mm (23.6")
Packaging Dimensions	1050mm (41.3") x 550mm (21.7") x 250mm (9.8")
Shipping Weight	20Kg (44lb)
Movement Type	Motorised
Power Supply Required	110V or 240V AC
Power Consumption	250-500W
Power Consumption Standby	3W
Decibel Rating	58dB
Mounting Patterns Supported	VESA 200 W x 300, 200 H
Control Options	IR Remote, RS232, Contact Closure
Product Options / Features	Specific B&O and Loewe mounts / adapters, Custom RAL paint finishes, Outdoor version
Package Contents	Mechanism, IR remote control, Push Flap Kit, Box Enclosure Kit
Marine Suitable	Yes (Indoor)

LSL-BE/PF 3

LIFT SYSTEM FOR BOX ENCLOSURE/PUSH FLAP



CABLE ROUTING

Screen cables are routed behind the Base Panel and out the right side of the Beam into the Cable Track. Cables must be routed carefully to prevent any interference with the LSL beam as it operates.

Screen and Mechanism cables should be routed to a control box in the bottom of the cabinet.

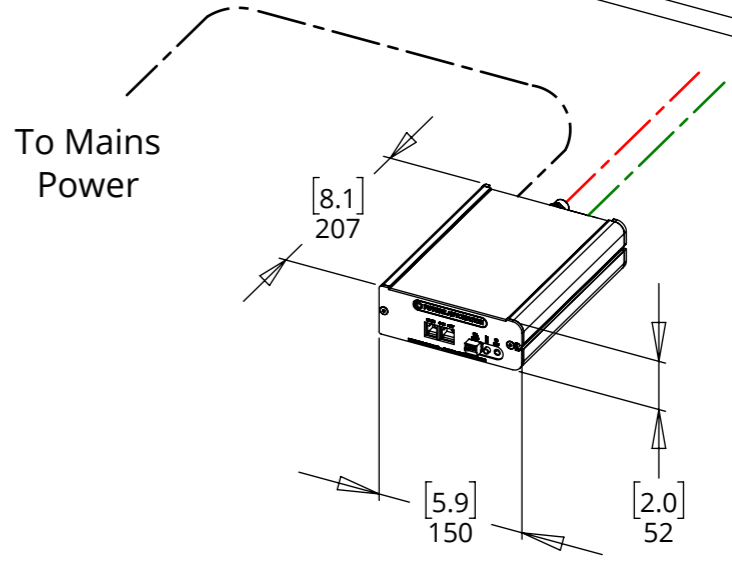
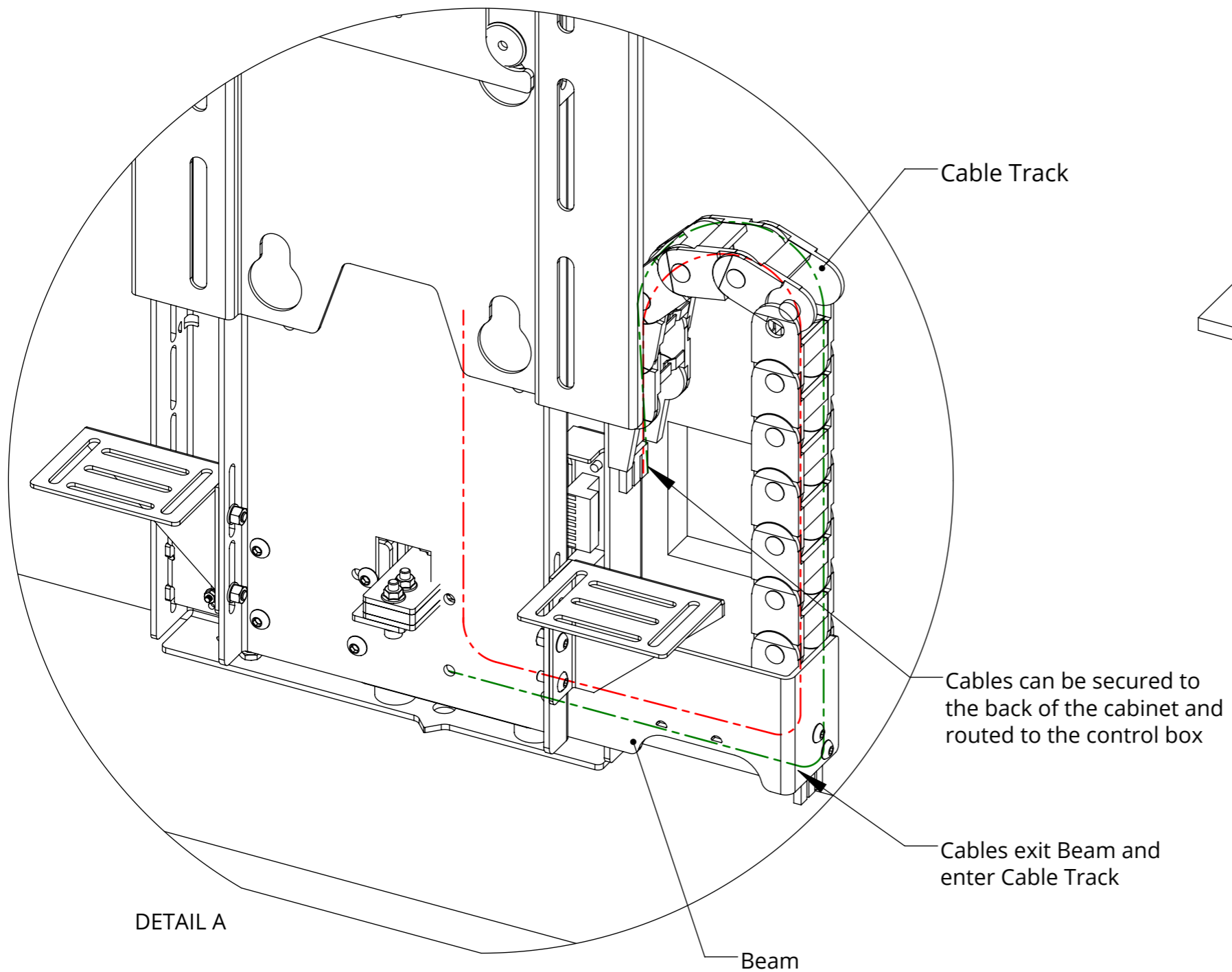
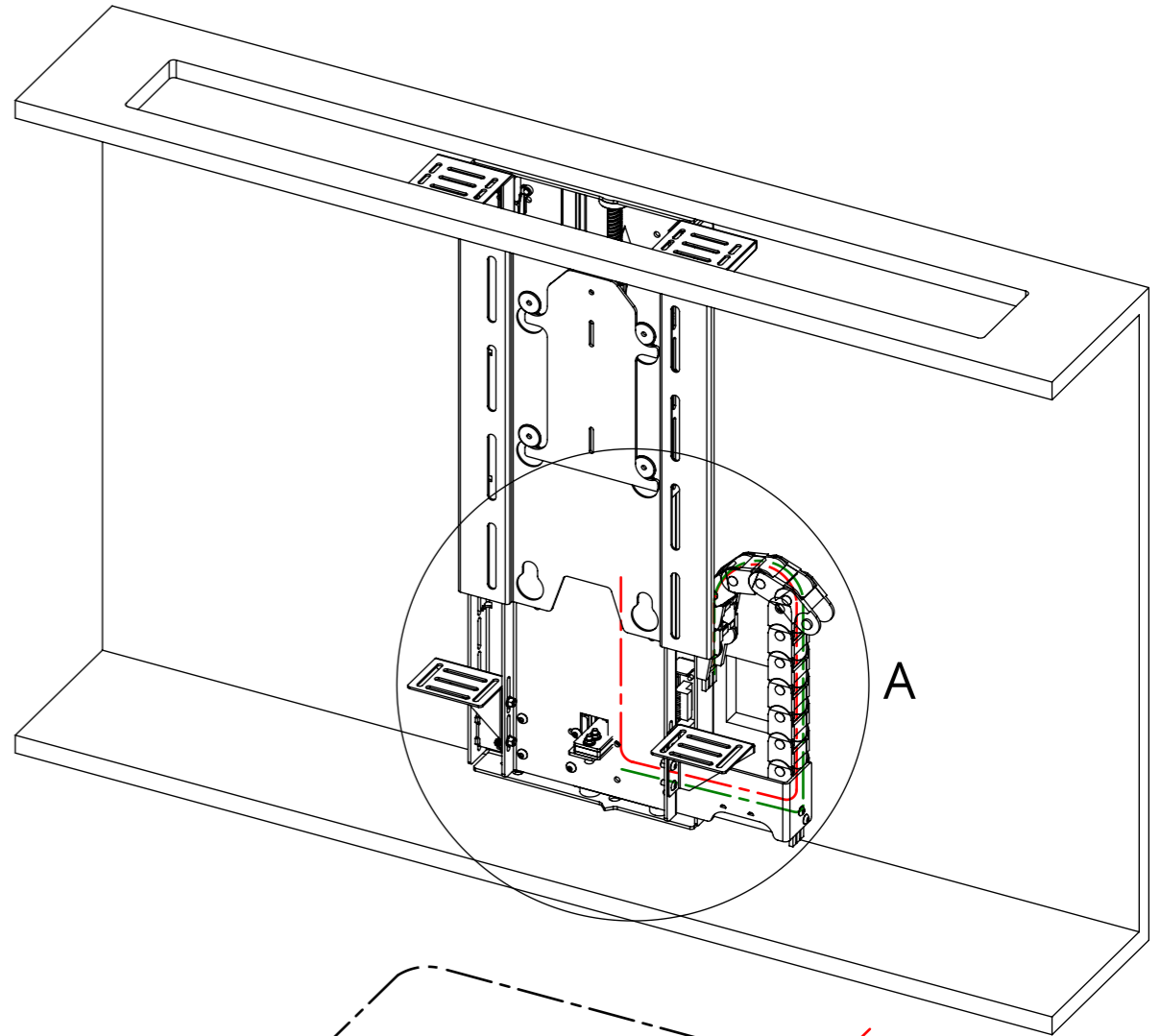

LSL-BE/PF 3

LIFT SYSTEM FOR BOX ENCLOSURE/PUSH FLAP

LSL-BE 3 - MECHANISM UP - IN CABINET

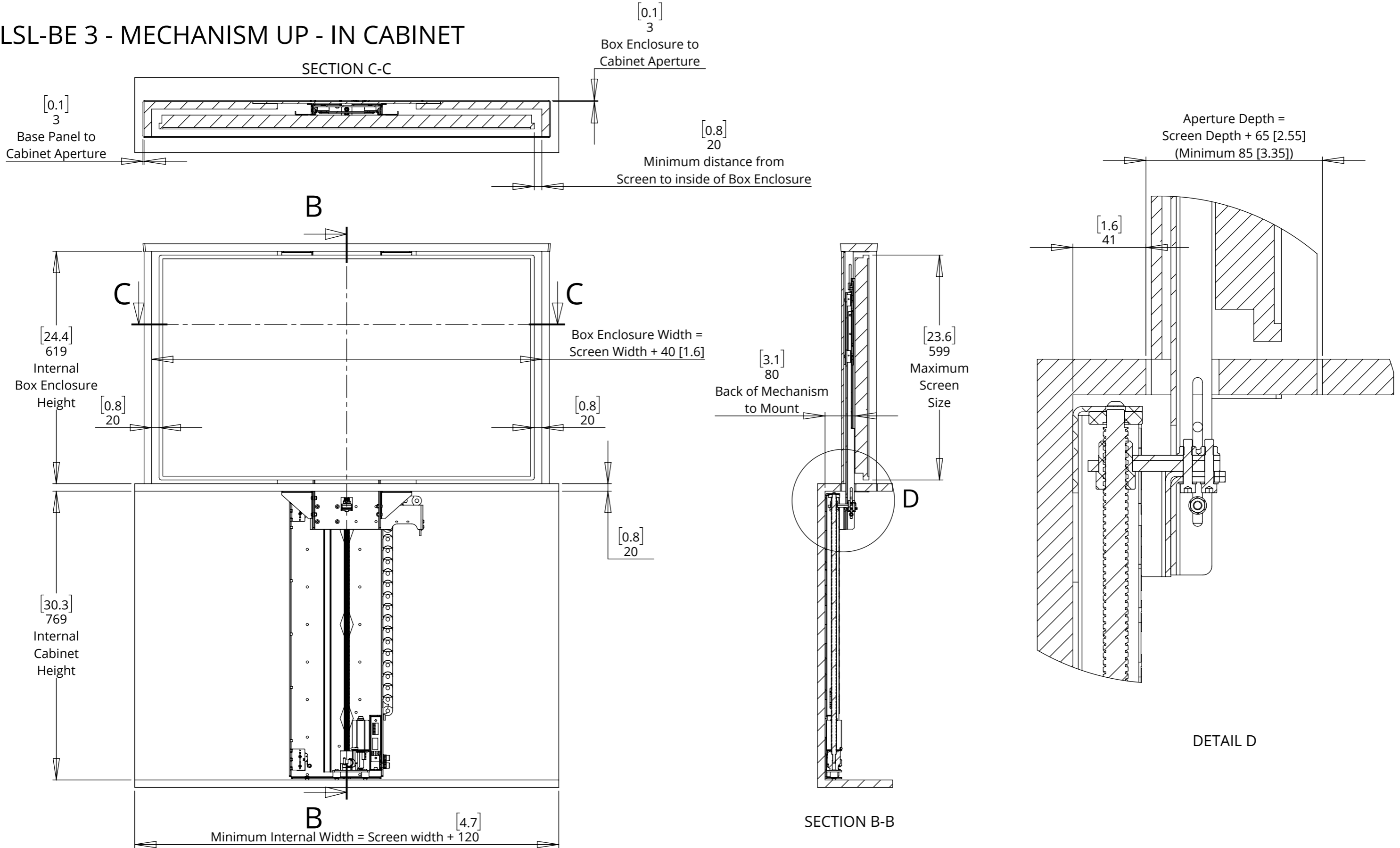

LSL-BE/PF 3

LIFT SYSTEM FOR BOX ENCLOSURE/PUSH FLAP



future automation

LSL-BE 3 - MECHANISM DOWN - IN CABINET

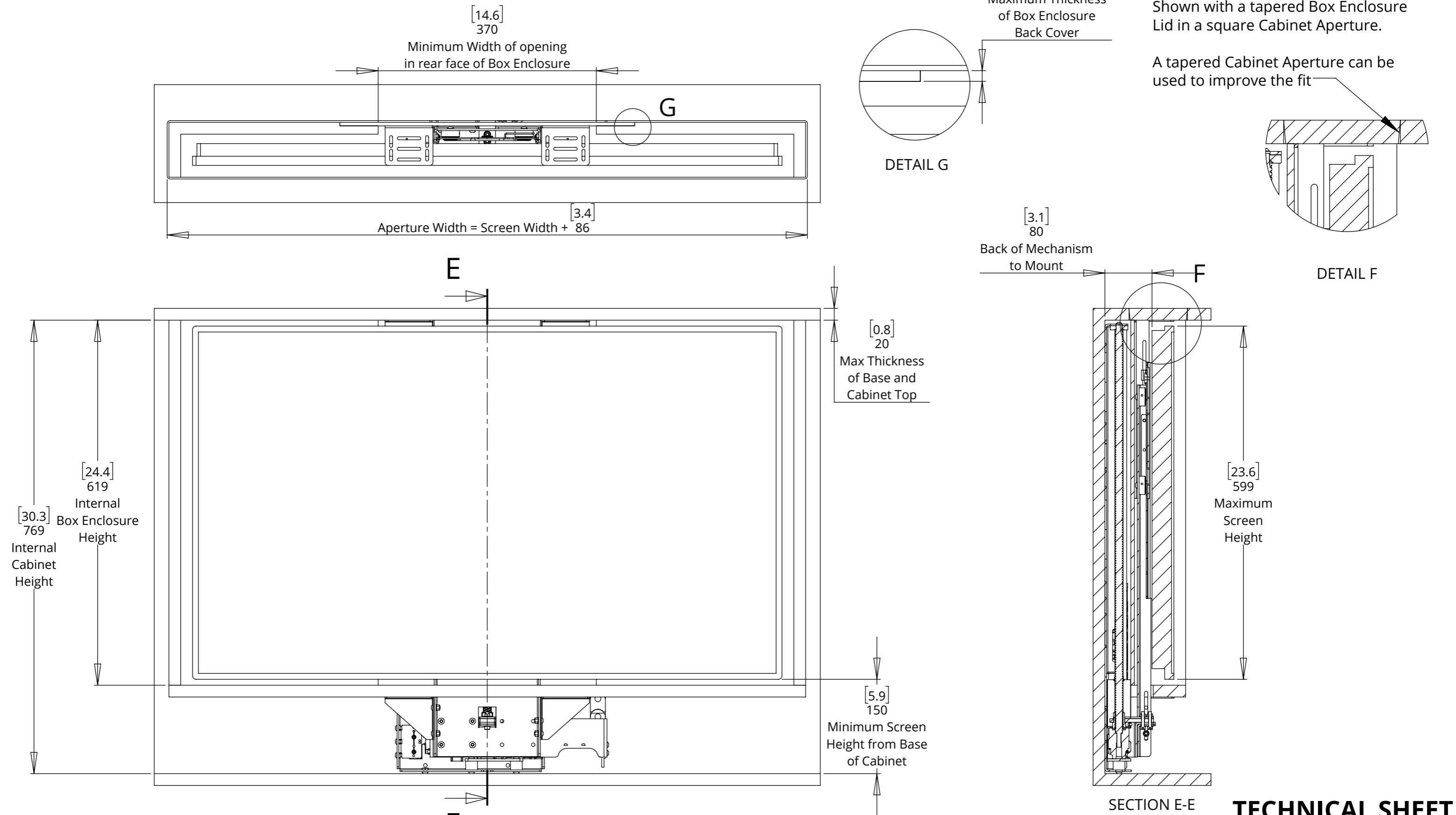

LSL-BE/PF 3

LIFT SYSTEM FOR BOX ENCLOSURE/PUSH FLAP



LSL-BE 3 - BASE PANEL & LID DETAILS

NOTE: A tapered Box Enclosure Lid creates a good fit in the Cabinet Aperture and helps the Box Enclosure to locate within the Cabinet.

BOX ENCLOSURE LID (TAPERED) - TOP VIEW

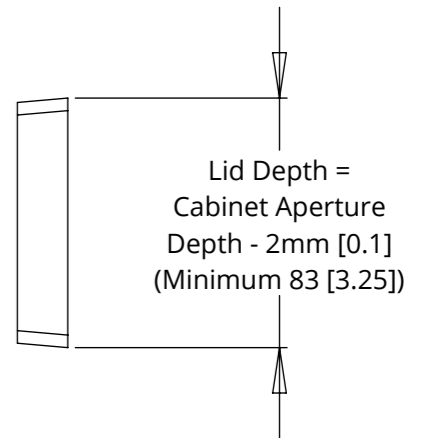

BASE PANEL - TOP VIEW

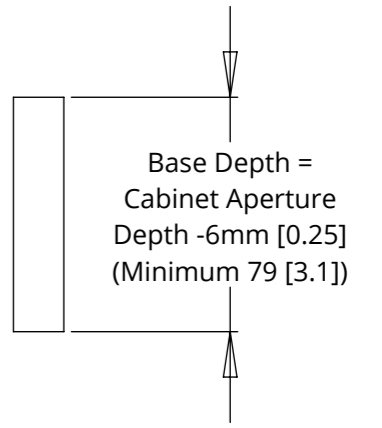
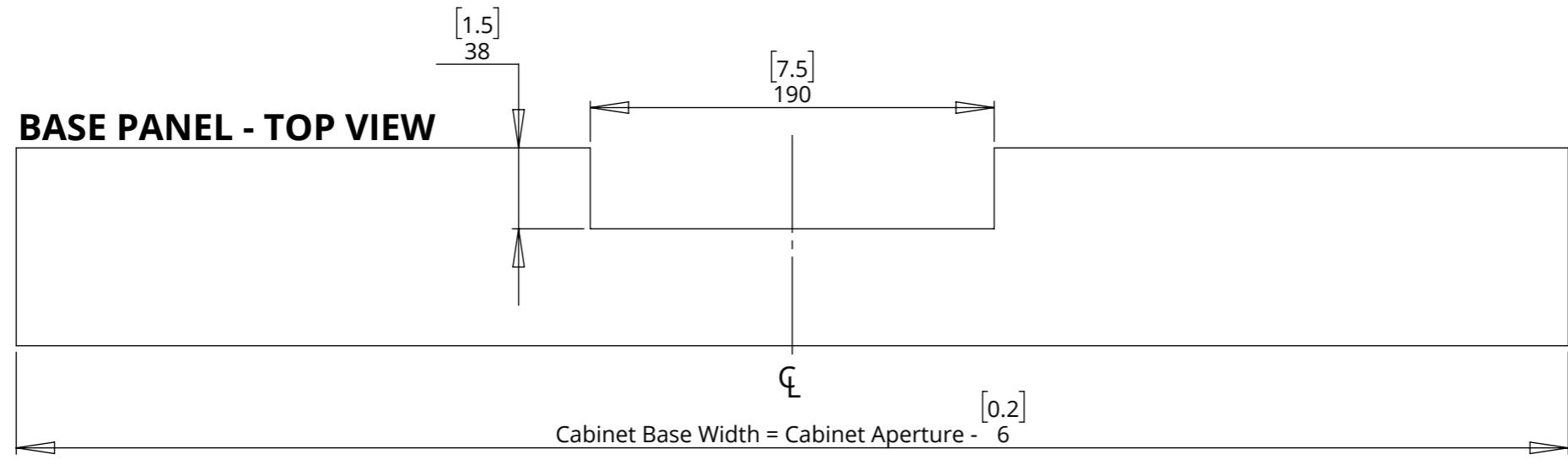

LSL-BE/PF 3

LIFT SYSTEM FOR BOX ENCLOSURE/PUSH FLAP

LSL-PF 3 - MECHANISM UP - IN CABINET

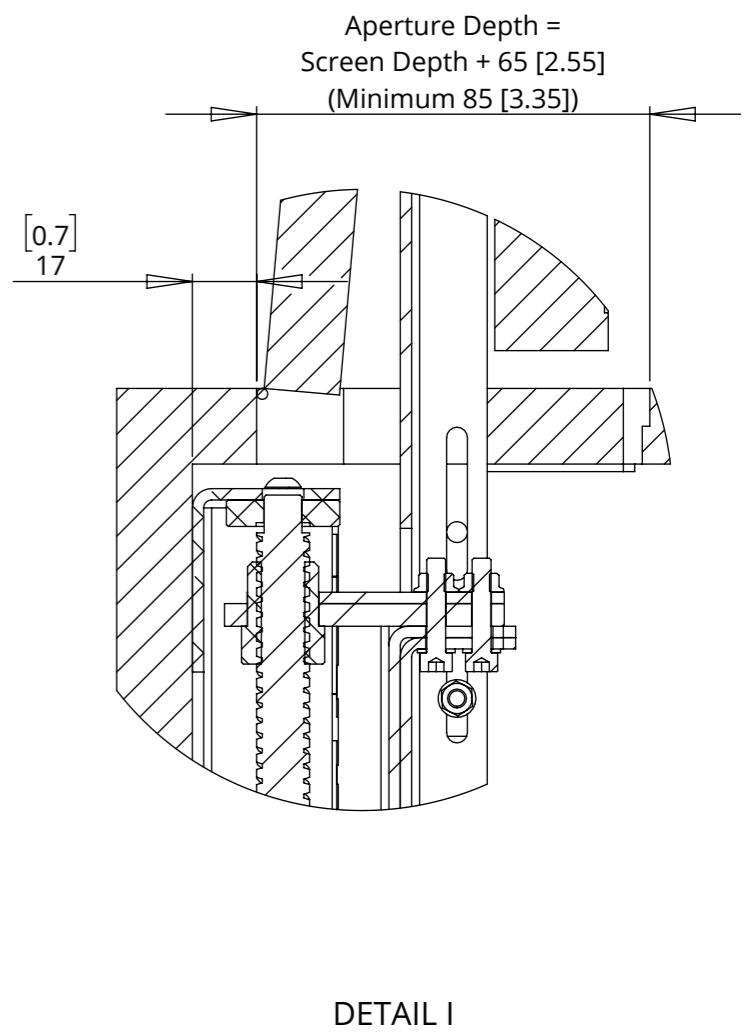
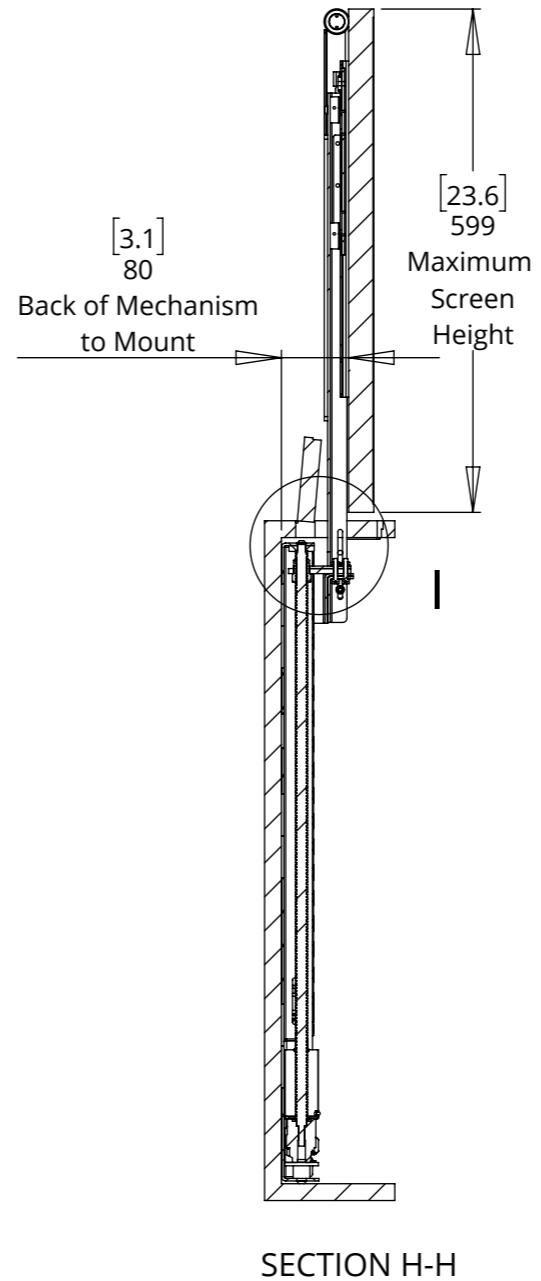
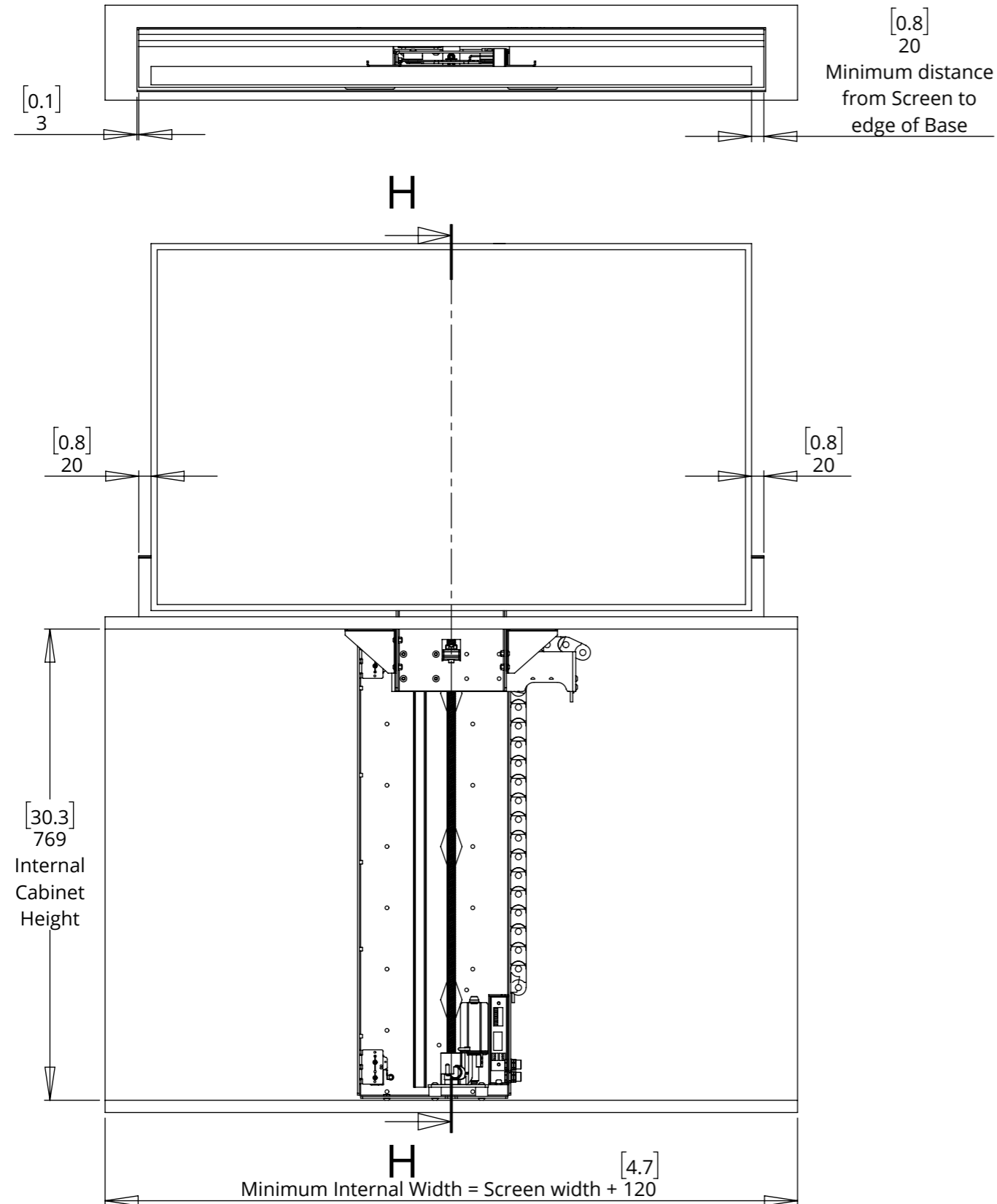

LSL-BE/PF 3

LIFT SYSTEM FOR BOX ENCLOSURE/PUSH FLAP



future automation

LSL-PF 3 - MECHANISM DOWN - IN CABINET

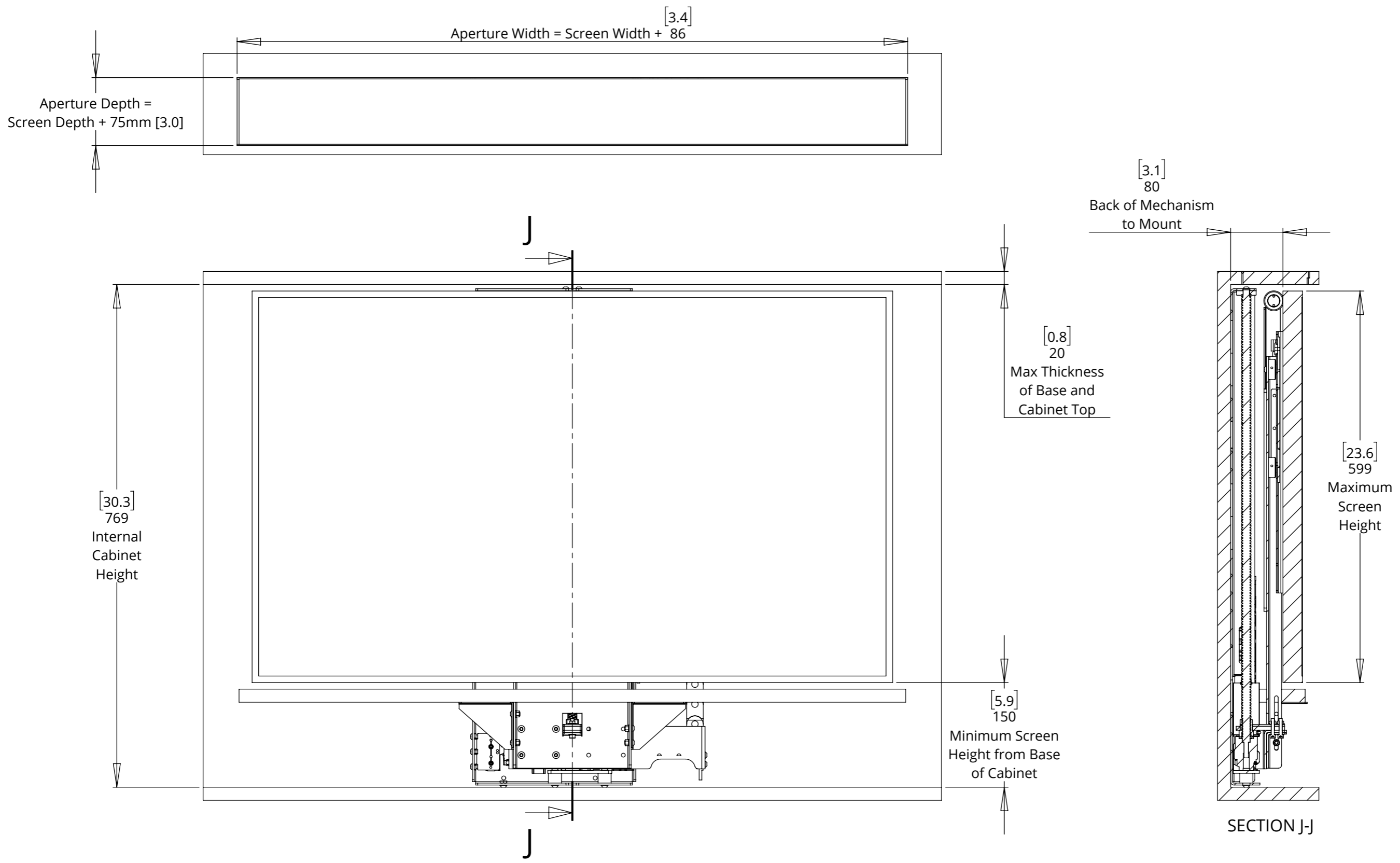

LSL-BE/PF 3

LIFT SYSTEM LIGHT FOR PUSH UP FLAP

LSL-PF 3 - BASE PANEL & FLAP DETAILS

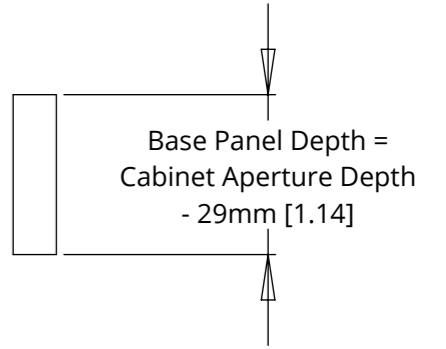
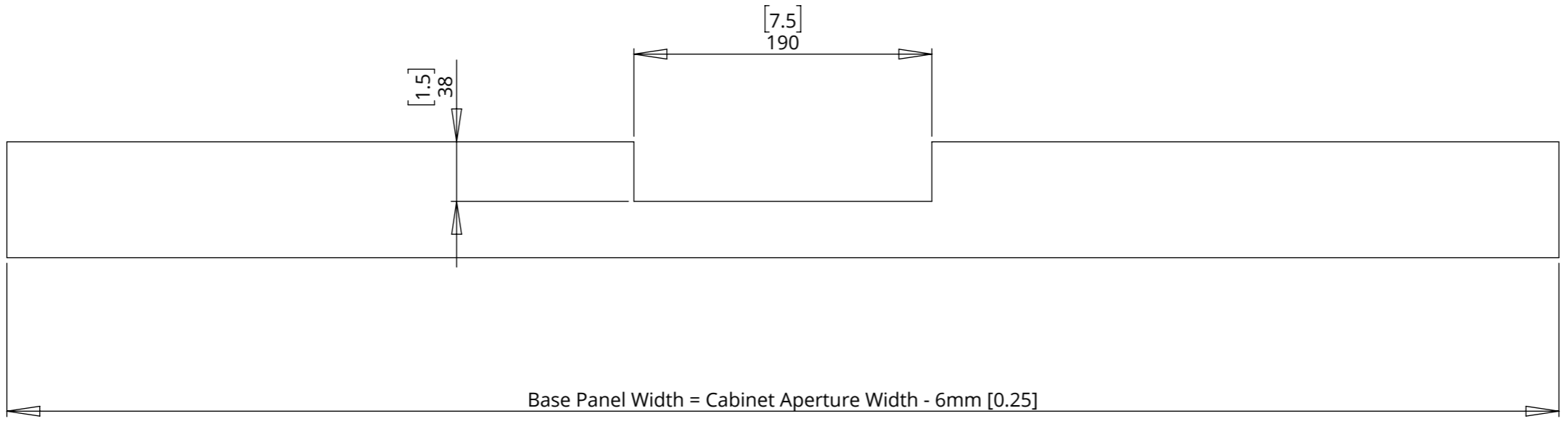
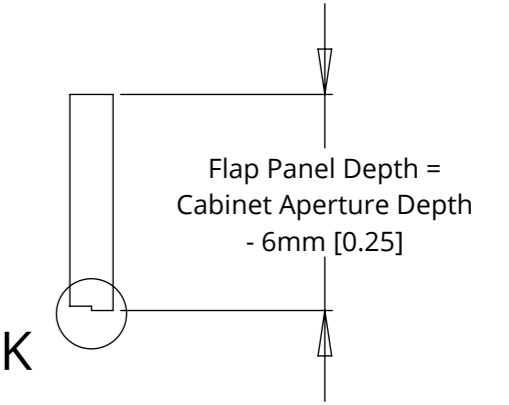
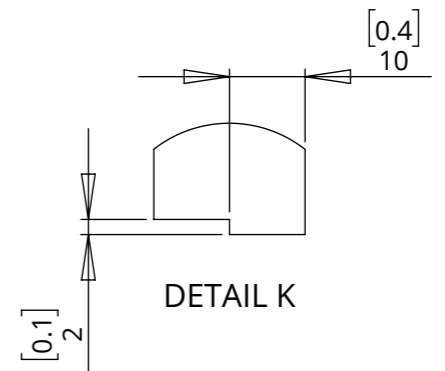

LSL-BE/PF 3

LIFT SYSTEM FOR BOX ENCLOSURE/PUSH FLAP



MECHANISM INSTALLATION OVERVIEW

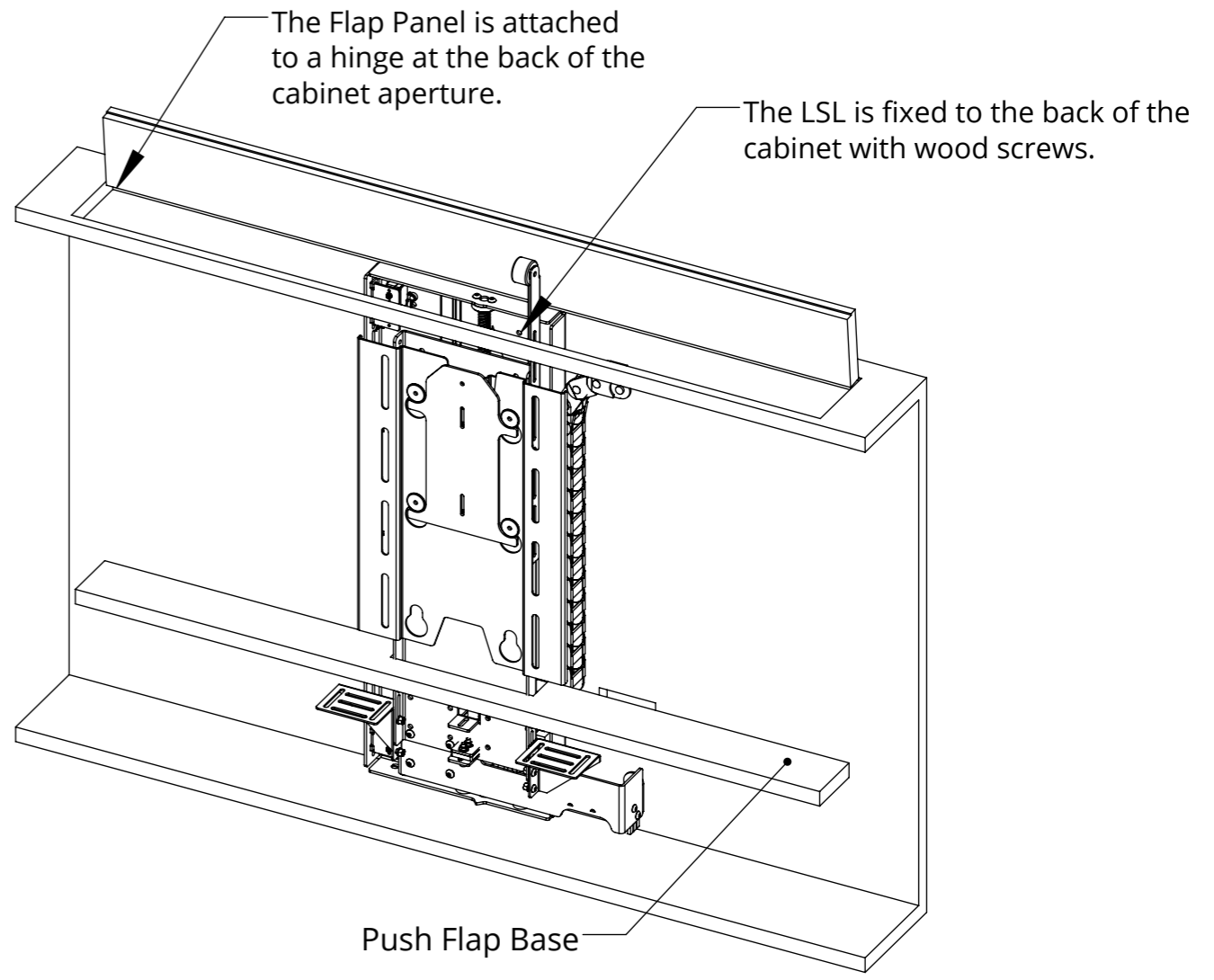
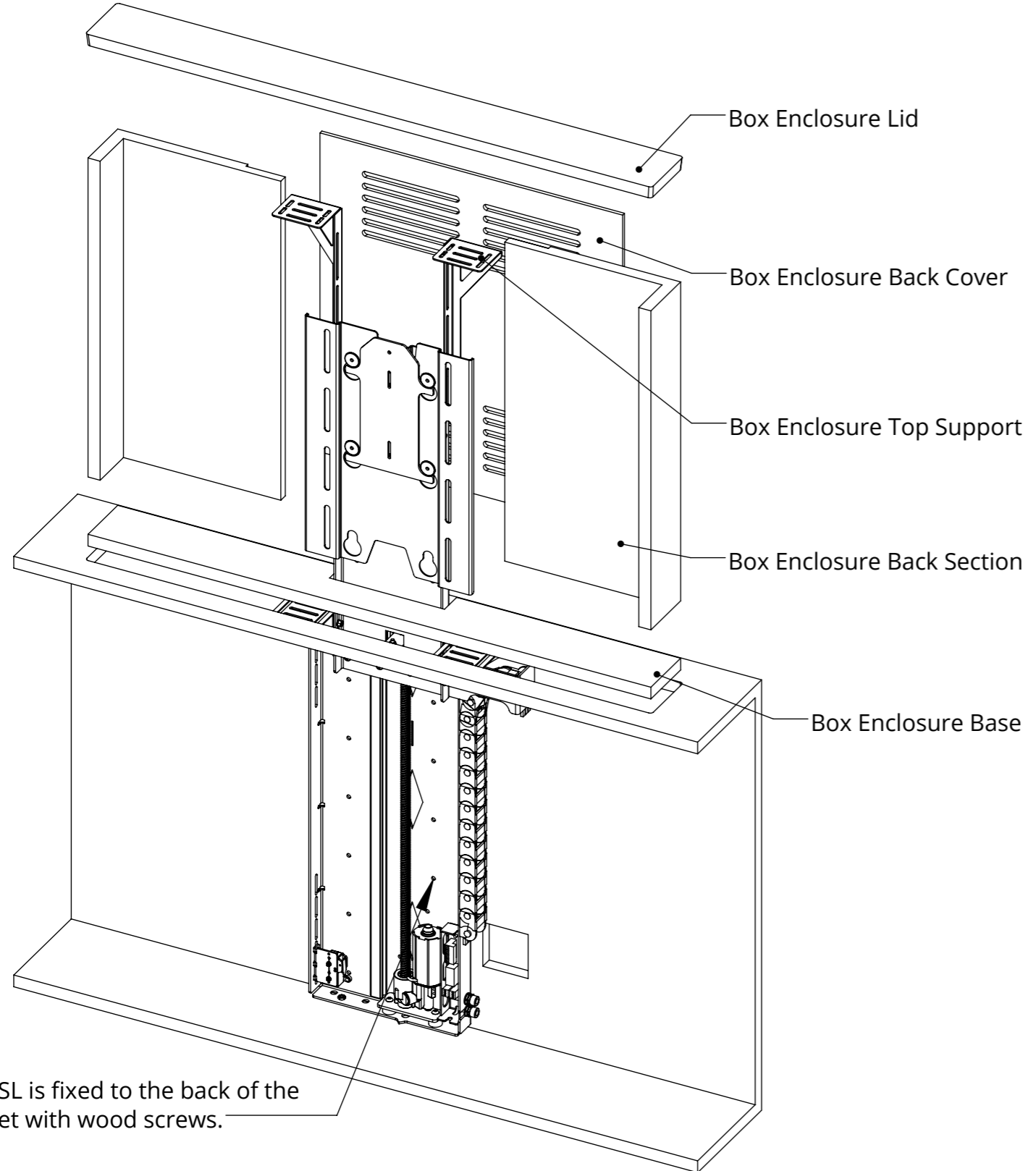

LSL-BE/PF 3

LIFT SYSTEM FOR BOX ENCLOSURE/PUSH FLAP



future automation

OVERALL MECHANISM DIMENSIONS

MECHANISM UP

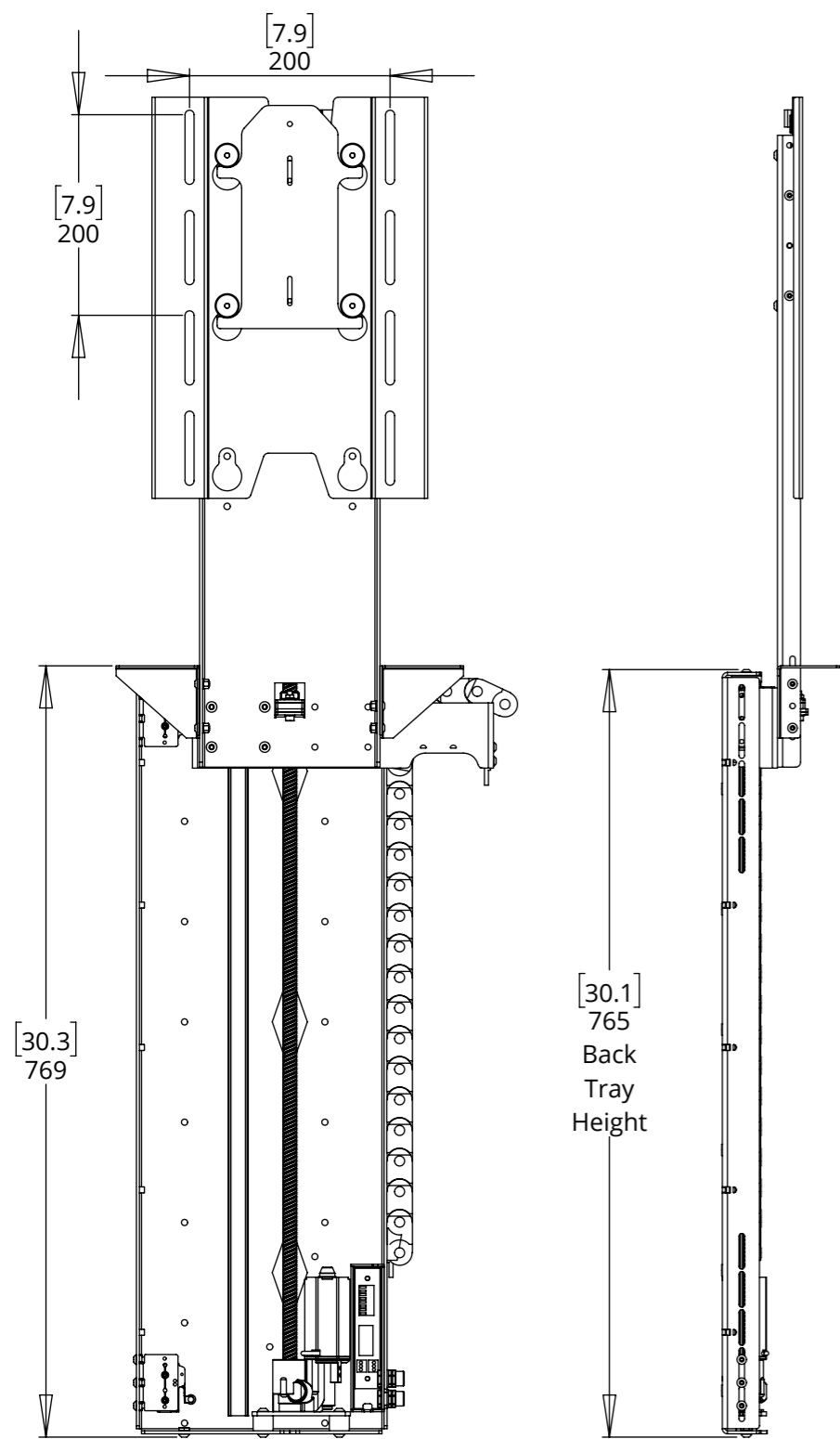

MECHANISM DOWN

